

◇ **Features:**

- 3.2mm x 1.0mm SMT LED, 1.50mm thickness
- Mono-color type
- Soldering methods :All SMT assembly methods
- Comply ROHS standard

◇ **Description**

The Red source color devices are made with AlGaInP on sapphire Light Emitting Diode.

The Yellow Green source color devices are made with AlGaInP on sapphire Light Emitting Diode.

◇ **Application**

- Optical indicator
- Indicator and backlighting in telephone and fax
- Flat backlight for LCD, switch and symbol
- Light pipe application
- General use

◇ **Package Dimensions**

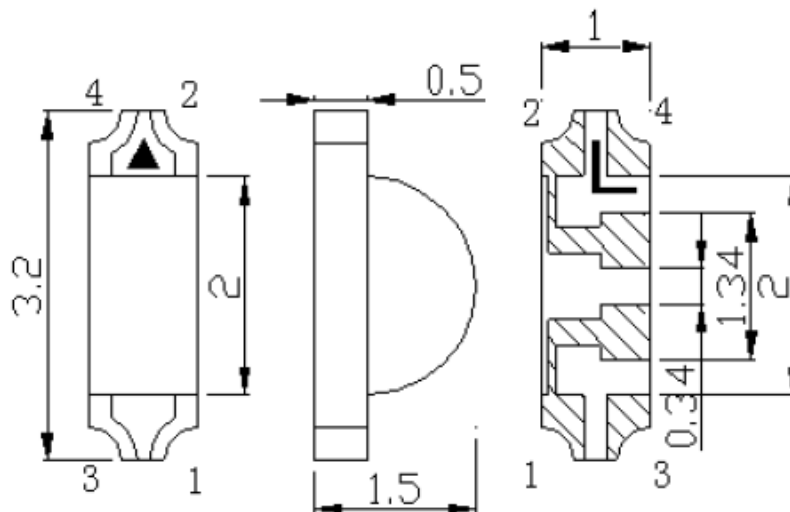

NOTES:

1. All dimensions are in millimeter[unit];
2. Tolerance is±0.1mm(0.004") unless other specified;
3. Specifications are subject to change without notice.

Emitted Color	Lens Color	Chip Material
Red	Water clear	AlGaInP
Yellow Green	Water clear	AlGaInP

✧ Absolute Maximum Ratings($T_a=25^\circ\text{C}$)

Item	Symbol	Maximum		Unit
		UR	UG	
Power Dissipation	PD	75	75	mW
Continuous Forward Current	I_{Fmax}	30	30	mA
Peak Forward Current(1/10 Duty Cycle 0.1ms Pulse Width)	I_{FP}	80	80	mA
Reverse Voltage	V_R	5	5	V
Operating Temperature Range	T_{opr}	-40 to+85		$^\circ\text{C}$
Storage Temperature Range	T_{stg}	-40 to+85		$^\circ\text{C}$

✧ Electrical/Optical Characteristics($T_a=25^\circ\text{C}$)

Item	Symbol	Condition	Min.		Typ.		Max		Unit
			UR	UG	UR	UG	UR	UG	
Forward Voltage	V_F	$I_F=20\text{mA}$	--	--	1.9	1.9	2.1	2.2	V
Luminous Intensity	I_V	$I_F=20\text{mA}$	100	25	200	50	--	--	mcd
Dominate Wavelength	λ_d	$I_F=20\text{mA}$	--	--	620	568	625	572	nm
Viewing Angle	$2\theta_{1/2}$	$I_F=20\text{mA}$	---	---	120	120	---	---	Deg
Reverse Current	IR	$V_R=5\text{V}$	---	---	---	---	10	10	μA

❖ Typical Electro-Optical Characteristics Curves (Red)

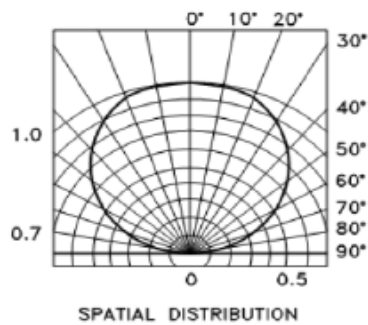
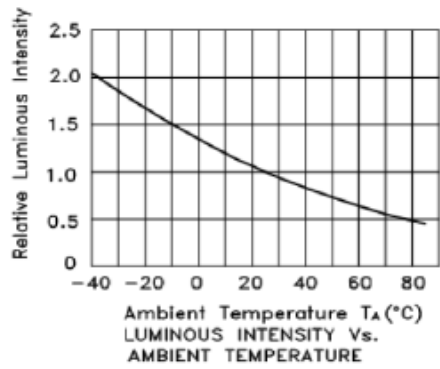
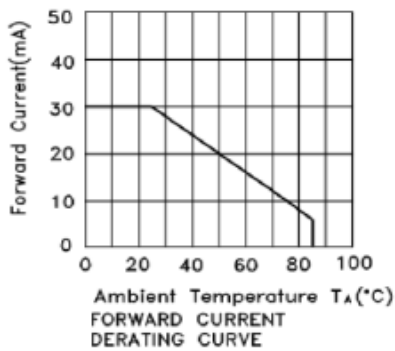
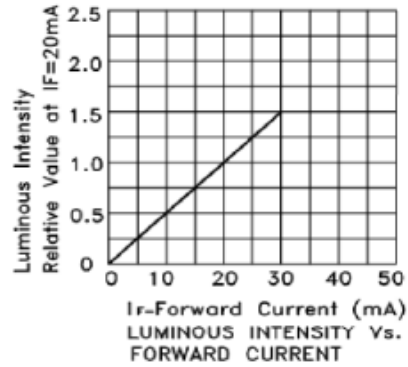
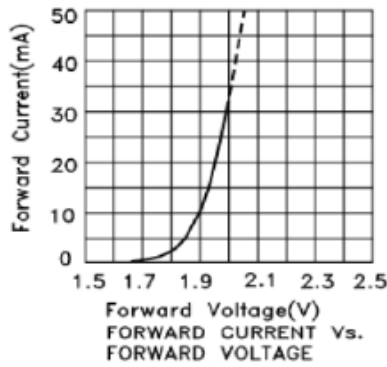
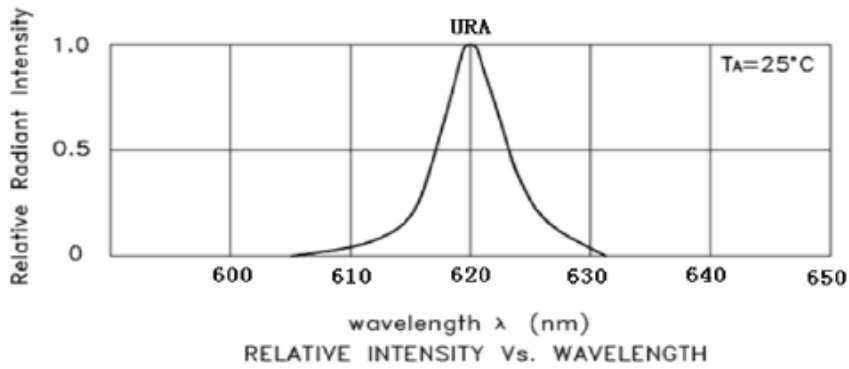

❖ Typical Electro-Optical Characteristics Curves (Yellow Green)

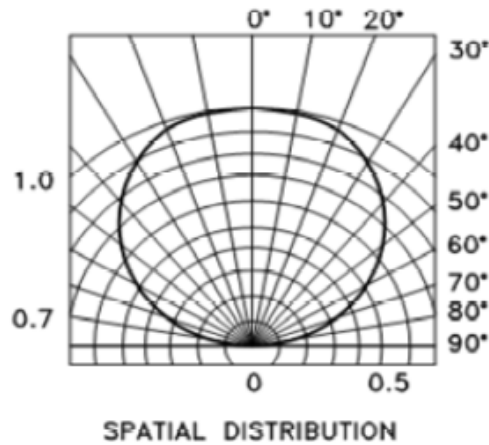
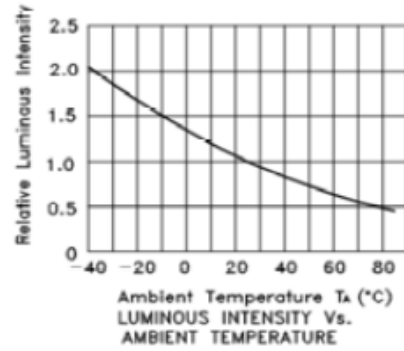
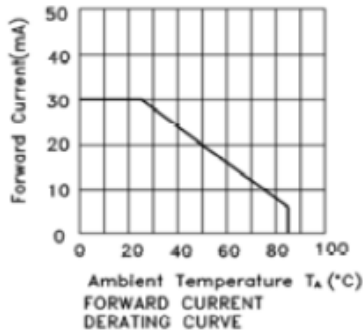
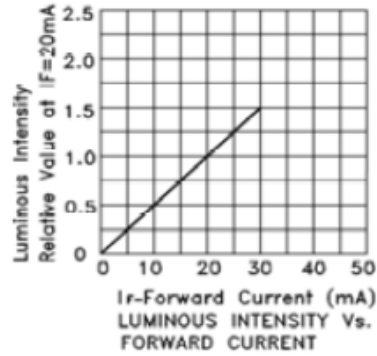
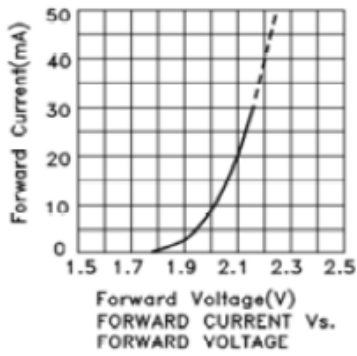
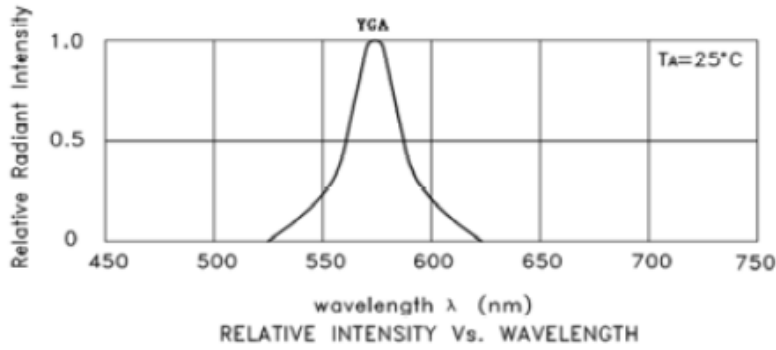

❖ Reliability Test Items And Conditions

NO.	Item	Test Condition	Test Hr/cycle/time	Sample Q'ty	Ac/Re
1	Reflow	TEMP:260±5°C; Min.5Sec	6 min	22pcs	0/1
2	Temperature Cycle	H:+100°C 15mins To(5mins) L:-40°C 15mins	300 cycles	22pcs	0/1
3	Thermal Shock	H:+100°C 15mins To(5mins) L:-40°C 15mins	300 cycles	22pcs	0/1
4	High Temperature Storage	TEMP:+260°C	1000hrs	22pcs	0/1
5	Low Temperature Storage	TEMP:-40°C	1000hrs	22pcs	0/1
6	DC Operating Life	IF=20MA	1000hrs	22pcs	0/1
7	High Temperature	85°C	1000hrs	22pcs	0/1
8	High Humidity	85%R.H.	1000hrs	22pcs	0/1

Rework

1. Customer must finish rework within 5 sec under 245°C.
2. The head of iron can not touch copper foil.
3. Twin-head type is preferred.

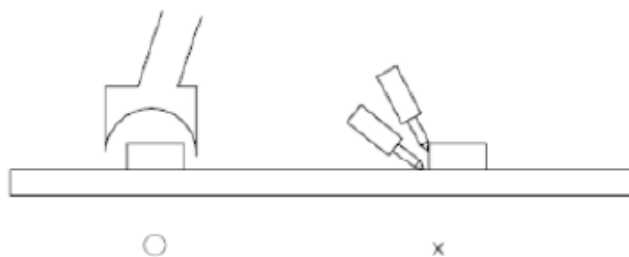

❖ **Precautions For Use**

1. Over-current-proof

Customer must apply resistors for protection , otherwise slight voltage shift will cause big current change (Burn out will happen).

2. Storage time

2.1 The operation of Temperature and RH are : 5°C~35°C, RH60%.

2.2 Once the package is opened, the products should be used within a week. Otherwise, they should be kept in a damp proof box with desiccating agent. Considering the tape life , we suggest our customers to use our products within a year(from production date).

2.3 If opened more than one week in an atmosphere 5°C~35°C, RH 60%, they should be treated at 60°C± 5°C for 15hrs.

2.4 When you discover that the desiccant in the package has a pink color (Normal = blue) , you should treat them in the same conditions as 2.3.

Soldering heat

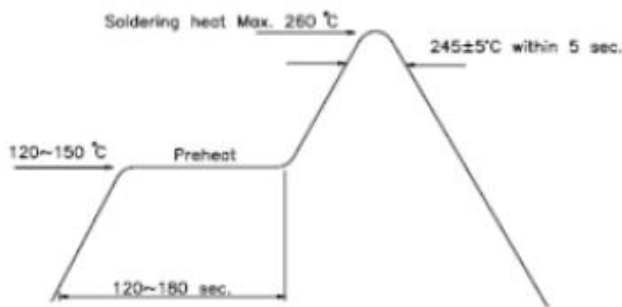

Reflow Temp / Time

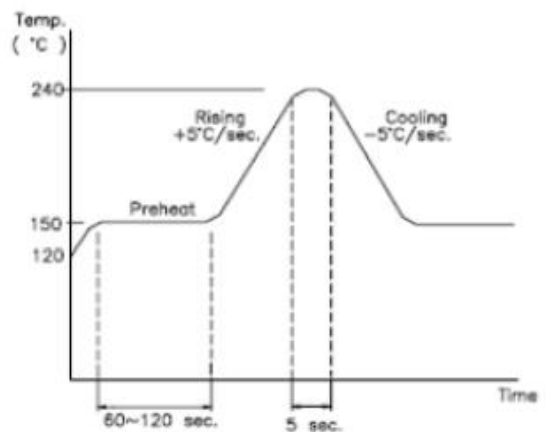

Soldering Iron

Basic spec is ≤ 5 sec when 260°C. If temperature is higher, time should be shorter (+10°C → -1sec). Power dissipation of Iron should be smaller than 15 W , and temperature should be controllable. Surface temperature of the device should be under 230 °C.

❖ Recommended Soldering Pad Dimensions

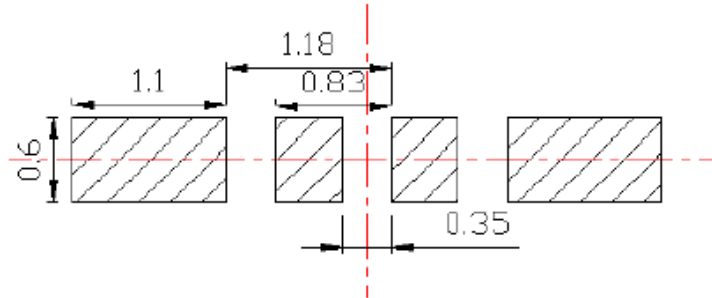

❖ Tape Specification: 2,000PCS per reel

