

SE-10S-PR

■Features

- Highest luminous flux
- Super energy efficiency
- Very long operating life (up to 100K hours)
- Superior ESD protection/ No UV
- AllnGaP Chip
- Water Clear Silicone

■Applications

- Read lights (car, bus, aircraft)
- Portable (flashlight, bicycle)
- Bollards / Security / Garden
- Traffic signaling / Beacons
- In door / Out door Commercial lights
- Automotive Ext

■Outline Dimension

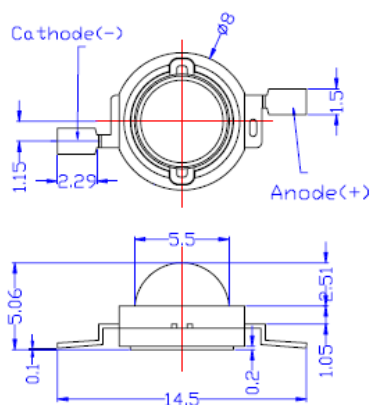

Unit:mm
Tolerances are for reference only

■Absolute Maximum Rating

(Ta=25°C)

Item	Symbol	Value	Unit
DC Forward Current	I_F	400	mA
Pulse Forward Current*	I_{FP}	500	mA
Reverse Voltage	V_R	5	V
Power Dissipation	P_D	1200	mW
Operating Temperature	T_{opr}	-30 ~ +85	°C
Storage Temperature	T_{stg}	-40~ +100	°C
Lead Soldering Temperature	T_{sol}	260°C/5sec	-

*Pulse width Max.10ms Duty ratio max 1/10

■Directivity

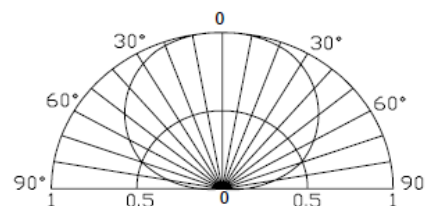

■Electrical -Optical Characteristics

(Ta=25°C)

Item	Symbol	Condition	Min.	Typ.	Max.	Unit
DC Forward Voltage	V_F	$I_F=350mA$	2.0	2.5	3.0	V
DC Reverse Current	I_R	$V_R=5V$	-	-	10	μA
Peak Wavelength	λ_p	$I_F=350mA$	628	-	640	nm
Luminous Flux	Φ_v	$I_F=350mA$	40	50	70	lm
50% Power Angle	$2\theta_{1/2}$	$I_F=350mA$	-	140	-	deg

Note: Don't drive at rated current more than 5s without heat sink for Xeon 1 emitter series.

■Forward Operating Current (DC)

